

protect your values

**svt**  
FIRE PROTECTION

# PYRO-SAFE FLAMMOPLAST SP-A2

intumescent coating for structural steel  
in accordance with ETA-17/0394

Coatings

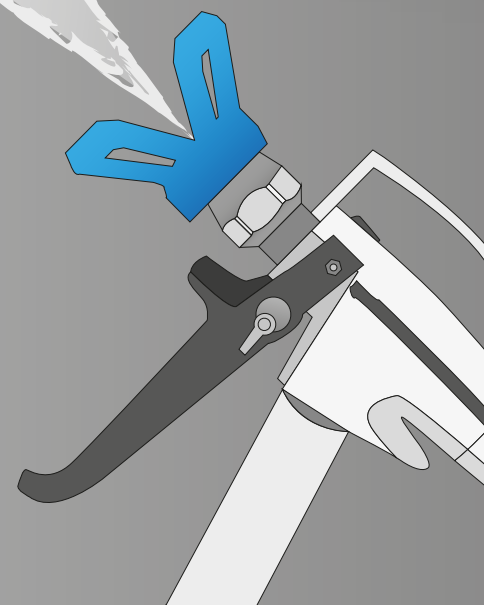

## Table of contents

Topic	Page
PYRO-SAFE FLAMMOPLAST SP-A2 and PYRO-SAFE Dekorlack SP 2 top coat	3 - 4
Three layers for perfect fire protection	5
Product properties	6
Required film thickness	7
<b>1. Preliminary notes / overview</b>	8
1.1 Target group	8
1.2 Using the manual	8
1.3 Safety information	8
1.4 Area of application	8
<b>2. Permissible uses</b>	9
<b>3. Usable products</b>	9
<b>4. Application</b>	10
4.1 Dew point table	11
<b>5. Suitability test of pre-coated steel surfaces</b>	12
<b>6. Application steps</b>	13 - 20
6.1 Processing information	13
6.2 Preparation of the surfaces	13
6.3 Film thickness measurement of the primer	14
6.4 Application steps PYRO-SAFE FLAMMOPLAST SP-A2	15 - 16
6.5 Film thickness measurement PYRO-SAFE FLAMMOPLAST SP-A2	16
6.6 Application steps PYRO-SAFE Dekorlack SP 2 topcoat	17 - 18
6.7 Film thickness measurement PYRO-SAFE Dekorlack SP 2	19

## Fire protection for structural steel

### PYRO-SAFE FLAMMOPLAST SP-A2 and PYRO-SAFE Dekorlack SP 2 top coat

Steel is a versatile material, thanks to its good material properties it is very popular in the construction industry. Due to its high strength, steel is particularly suitable for load-bearing structures and is an essential part of modern buildings.

But the strength of steel decreases rapidly on heating. Depending on the materials thickness and the surface exposed to the fire, temperatures of about 500 °C are critical. A sufficient strength is then no longer given and steel structures can not fulfill their static task. Together with a high thermal conductivity, this temperature range is reached very quickly. For that reason conventional, unprotected steel profiles achieve fire resistance durations of only 15 minutes.

An increase in the fire resistance duration can be achieved by various measures. An efficient and versatile application of the fire protection technology is the coating with intumescent materials, e.g. the PYRO-SAFE FLAMMOPLAST SP-A2.



## Fire protection for structural steel

### PYRO-SAFE FLAMMOPLAST SP-A2 and PYRO-SAFE Dekorlack SP 2 top coat

PYRO-SAFE FLAMMOPLAST SP-A2 essentially consists of intumescent substances and binding agents. The efficacy of the intumescent coating depends on the formation of a heat-insulating foam. In the event of a fire the intumescent coatings foam and form an insulating layer.

Traditional intumescent products involved a coating which would foam up voluminously on exposure to heat, expanding to as much as 100 times its original thickness without any appreciable expansion pressure and forming a light, fine-pored carbon foam, i.e. the insulating layer. Thanks to their highly insulating effect, these products are primarily used in structural steel engineering.



#### Benefits

- Easy application using brush, roller, airless spray gun or compressed air
- Economic application
- Various proofs for different primers and top coatings
- Individual colour design – top coatings of various suppliers are available in almost every colour
- Visual preservation of the steel construction and space-saving application thanks to low film thicknesses
- Very low static loads of the coated steel constructions
- Suitable for open and hollow sections
- Solvent free, contains no halogens
- Does not contain asbestos, lead, mercury, hexavalent chromium or polybrominated biphenyl
- Does not release toxic fumes



## Fire protection for structural steel

### Three layers for perfect fire protection

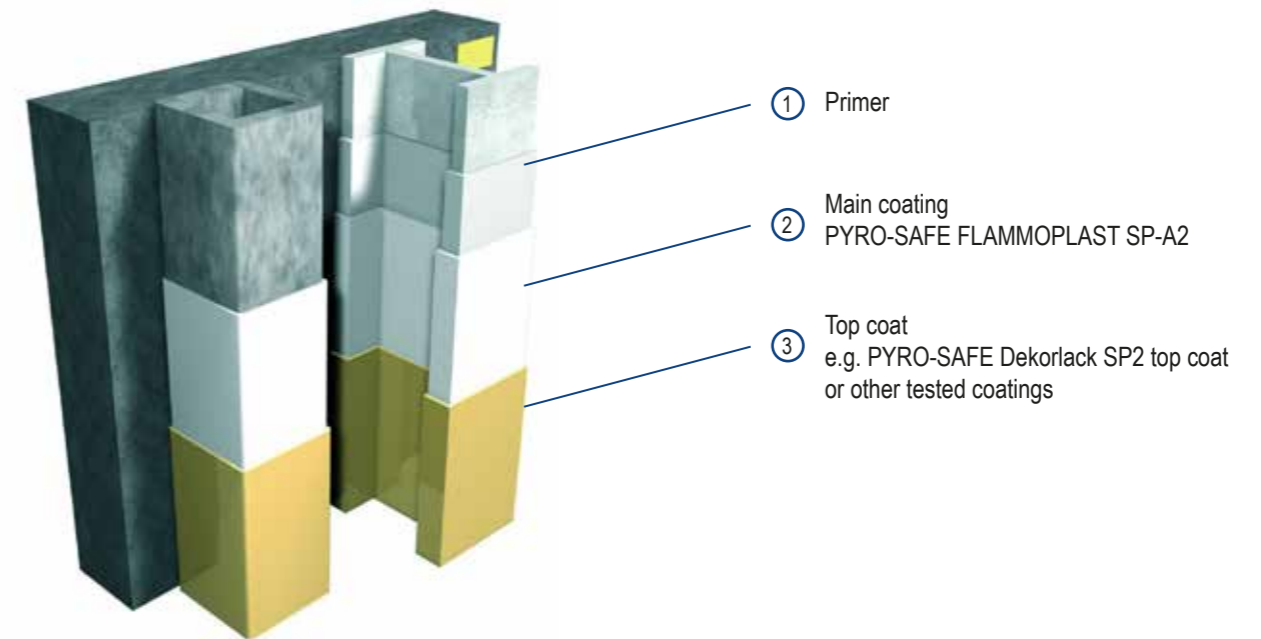

#### ① Primer

The primer is the first layer on the steel part and protects it from corrosion and is also an ideal adhesive surface for the main coat. Often steel parts are coated with a primer from the factory. PYRO-SAFE FLAMMOPLAST SP-A2 is developed in a way that various primers are suitable with it. In general three types of generic primer groups are approved:

- Short-/medium-chain oil alkyd resin
- Acryl
- Two-component epoxy resin

#### ② Main coating – PYRO-SAFE FLAMMOPLAST SP-A2

The fire protection coating PYRO-SAFE FLAMMOPLAST SP-A2 (consisting of a solvent-free, water-based dispersion with inorganic and organic components) is developed for structural fire protection on static-bearing steel and forms the main coat.

Thanks to the foaming effect and the intumescent function, in case of a fire the steel construction will be enclosed and protected against fire. The heating is delayed, so that a fire resistance and load capacity of up to 30 minutes can be achieved.

The required layer thickness depends on the steel profile, the U/A-factor (ratio of the burned circumference to the cross-section area), the critical steel temperature and the fire resistance duration to be achieved. PYRO-SAFE FLAMMOPLAST SP-A2 can be applied by brush, roller or by spraying (airless or compressed air) and is suitable for dry indoor use.

#### ③ Top coat – PYRO-SAFE Dekorlack SP 2 top coat or further approved coatings

To protect the main coating a top coat is necessary. The PYRO-SAFE Dekorlack SP 2 top coat is a solvent free, watery dispersion based on acrylat. It is resistant to yellowing, fast drying, abrasion resistant, self-extinguishing and, in case of fire, it builds an insulating foam layer together with PYRO-SAFE FLAMMOPLAST SP-A2. The top coat is available in white and various RAL colours which enables a free decorative colour design.

Alternatively coatings from other producers can be used, too.



## Fire protection for structural steel

with PYRO-SAFE FLAMMOPLAST SP-A2 and PYRO-SAFE Dekorlack SP 2 top coat

### Product properties

PYRO-SAFE FLAMMOPLAST SP-A2		Coating			
Colour	White				
Density (+20 °C)	1.30 g/cm <sup>3</sup> - 1.46 g/cm <sup>3</sup>				
Volatile components (VOC)	< 140 g/l				
Viscosity (+20 °C) [mPas]	9,000 - 13,000				
Handling* (min. +5 °C/ < 85 % relative humidity)*	<ul style="list-style-type: none"> <li>• Brush</li> <li>• Roller</li> <li>• Airless spray gun (nozzle bore &lt; 0.019 inch = 0.48 mm)</li> <li>• Compressed air (nozzle bore ≥ 3.5 mm)</li> </ul>				
Consumption	Consumption / dry film thickness depends on:				
	<ul style="list-style-type: none"> <li>• Steel section (open or hollow)</li> <li>• U/A-factor (m<sup>-1</sup>)</li> <li>• Critical steel temperature T<sub>Kr</sub></li> <li>• Fire resistance class</li> </ul>				
	Solid material (weight)	Consumption example	Wet film thickness**	Dry film thickness**	
	62 - 72 %	1,000 g/m <sup>2</sup>	ca. 800 µm	ca. 480 µm	
Drying time dust-dry reworkable thoroughly dry (at +23 °C / relative air humidity 65 % ± 3 %)	min. 5 hours min. 8 hours min. 5 days				
Product No	01153300 white				

\* It is allowed to add water to the product for required processing viscosity. Clean the tools with water after work immediately.

\*\* Material losses must be taken into account during application.

PYRO-SAFE Dekorlack SP 2 top coat		Coating			
Colour	white, other colours				
Degree of gloss	satin gloss				
Density (+20 °C)	1.05 g/cm <sup>3</sup> - 1.35 g/cm <sup>3</sup>				
Volatile components (VOC)	< 140 g/l				
Viscosity (+20 °C) [mPas]	2,500 - 4,500				
Handling* (min. +5 °C/ < 85 % relative humidity)*	<ul style="list-style-type: none"> <li>• Brush</li> <li>• Roller</li> <li>• Airless spray gun (nozzle bore &lt; 0.013 - 0.017 inch = 0.33 - 0.43 mm)</li> <li>• Compressed air (nozzle bore 1.5 - 2.0 mm)</li> </ul>				
Consumption	150 g/m <sup>2</sup> ≈ dry film thickness** approx. 60 µm				
Drying time dust-dry reworkable thoroughly dry (at +23 °C / relative air humidity 65 % ± 3 %)	min. 1 hour min. 6 hours min. 4 days				
Product No	01153101 (RAL colour 9010 white) different RAL colours on request				

\* It is allowed to add water to the product for required processing viscosity. Clean the tools with water after work immediately.

\*\* Material losses must be taken into account during application.

## Fire protection for structural steel

with PYRO-SAFE FLAMMOPLAST SP-A2 and PYRO-SAFE Dekorlack SP 2 top coat

### Example for required dry film thicknesses PYRO-SAFE FLAMMOPLAST SP-A2

• Depending on the U/A-factor and the section of the component to be coated for a fire resistance duration of 30 minutes with a critical steel temperature (T<sub>Kr</sub>) of 500/550 °C.

• This table is an example only. Data with other parameters can be found in ETA-17/0394.

Example for necessary dry film thicknesses in mm						
U/A-factor [m <sup>-1</sup> ]	Open sections		Hollow sections			
	H and I		O		□	
	T <sub>Kr</sub> 500 °C	T <sub>Kr</sub> 550 °C	T <sub>Kr</sub> 500 °C	T <sub>Kr</sub> 550 °C	T <sub>Kr</sub> 500 °C	T <sub>Kr</sub> 550 °C
≤ 50						
55			0.209		0.250	0.205
60			0.207	0.209		
65	0.220		0.257		0.280	
70			0.304		0.316	0.201
75			0.351	0.202	0.352	0.231
80		0.220	0.396	0.239	0.387	0.259
85	0.222		0.441	0.276	0.421	0.287
90	0.233		0.484	0.313	0.454	0.315
95	0.244		0.525	0.348	0.486	0.342
100	0.255		0.566	0.382	0.517	0.368
105	0.265		0.606	0.416	0.548	0.393
110	0.276	0.225	0.645	0.449	0.578	0.418
115	0.287	0.233	0.683	0.482	0.607	0.443
120	0.297	0.241	0.720	0.513	0.635	0.467
125	0.308	0.248	0.756	0.544	0.663	0.490
130	0.319	0.256	0.791	0.575	0.690	0.513
135	0.330	0.263	0.826	0.604	0.717	0.536
140	0.340	0.271	0.860	0.634	0.743	0.557
145	0.351	0.278	0.893	0.662	0.768	0.579
150	0.362	0.286	0.925	0.690	0.793	0.600
155	0.373	0.293	0.956	0.718	0.818	0.621
160	0.383	0.301	0.987	0.745	0.841	0.641
165	0.394	0.309	1.017	0.771	0.865	0.661
170	0.405	0.316	1.047	0.797	0.888	0.680
175	0.415	0.324	1.076	0.822	0.910	0.699
180	0.426	0.331	1.104	0.847	0.932	0.718
185	0.437	0.339	1.131	0.872	0.953	0.736
190	0.448	0.346	1.159	0.896	0.974	0.754
195	0.458	0.354	1.185	0.919	0.995	0.772
200	0.469	0.361	1.211	0.942	1.015	0.789
205	0.480	0.369	1.237	0.965	1.035	0.806
210	0.490	0.377	1.262	0.988	1.054	0.822
215	0.501	0.384	1.286	1.009	1.073	0.839
220	0.512	0.392		1.031	1.092	0.855
225	0.523	0.399		1.052	1.110	0.871
230	0.533	0.407		1.073	1.128	0.886
235	0.544	0.414		1.094	1.146	0.901
240	0.560	0.422		1.114	1.163	0.916
245	0.583	0.429		1.133	1.180	0.931
250	0.605	0.437		1.153	1.197	0.945
255	0.628	0.445		1.172	1.214	0.960
260	0.650	0.452		1.191	1.230	0.974
265	0.673	0.460		1.209	1.246	0.987
270	0.696	0.467		1.228	1.261	1.001
275	0.718	0.475		1.246	1.277	1.014
280	0.741	0.482		1.263		1.027
285	0.764	0.490		1.281		1.040
290	0.786	0.497		1.298		1.042
295	0.809	0.505				
300	0.833	0.512				
305	0.887	0.520				
310	0.940	0.528				
315	0.994	0.535				
320	1.047	0.543				
325	1.101	0.553				
330	1.154	0.633				
335	1.208	0.714				
340		0.794				
345		0.905				
350		1.040				
355		1.175				

# Fire protection for structural steel

with PYRO-SAFE FLAMMOPLAST SP-A2 and PYRO-SAFE Dekorlack SP 2 top coat

## 1. Preliminary notes / overview

### 1.1 Target group

- The installation instructions are intended solely for personnel trained in fire protection.

### 1.2 Using the manual

- Read this manual thoroughly first before beginning work. Pay particular attention to the following safety information:
- The authorisation holder assumes no liability for damages which arise through a failure to comply with this guide.
- Pictorial representations serve purely as examples. Installation results may differ visually.

### 1.3 Safety instructions



#### Personal protective equipment:



body protection  
wear protective work clothing and non-slip shoes

### 1.4 Area of application

PYRO-SAFE FLAMMOPLAST SP-A2 coating is designed for use on components requiring fireproofing in or on building products, structural elements, building types and structures which are subject to fire protection specifications. In the event of a fire, the coating prevents the heat from penetrating by foaming up on exposure to high temperatures.

- PYRO-SAFE FLAMMOPLAST SP-A2 is developed for structural fire protection on static-bearing steel.
- The fire protection coating „PYRO-SAFE FLAMMOPLAST SP-A2“ fulfills the type Z<sub>2</sub> in accordance with EOTA TR 024. PYRO-SAFE FLAMMOPLAST SP-A2 can be subjected to the conditions of inside rooms with or without exposure to moisture, without substantial changes to the fire protection characteristics being expected.
- PYRO-SAFE FLAMMOPLAST SP-A2 must not be exposed to moisture or direct atmospheric influences.
- PYRO-SAFE FLAMMOPLAST SP-A2 may only be painted with other colours which are approved by svt.
- If special demands are imposed on the PYRO-SAFE FLAMMOPLAST SP-A2 coating, for instance constant exposure to chemicals, then additional evidence is required.

# Fire protection for structural steel

with PYRO-SAFE FLAMMOPLAST SP-A2 and PYRO-SAFE Dekorlack SP 2 top coat

## 2. Permissible uses

	<p><b>Steel with preparation standard Sa 2½</b></p> <p>Beams, supports and framework with open and hollow sections</p>
--	--

## 3. Usable products

	<p><b>Primer</b></p> <p>Suitable and tested primers:</p> <ul style="list-style-type: none"> <li>• Permacor 1705 – sika</li> <li>• IMOCRYL ALLGRUND – IMPARAT</li> <li>• Epinox 98 – Teknos</li> </ul> <p>Approved primer groups whose suitability has to be tested in accordance with p.12:</p> <ul style="list-style-type: none"> <li>• Short-/medium-chain oil alkyd resin</li> <li>• Acryl</li> <li>• Two-component epoxy resin</li> </ul>
--	---

	<p><b>PYRO-SAFE FLAMMOPLAST SP-A2</b></p> <p>Intumescent material in accordance with ETA-17/0394</p> <p>12.5 kg pail – <b>product No. 01153300</b> various packaging sizes on request.</p>
--	--

	<p><b>PYRO-SAFE Dekorlack SP 2</b></p> <p>top coat</p> <p>12.5 kg pail (RAL colour 9010 white) – <b>product No. 01153101</b> various packaging sizes and RAL colours on request.</p> <p>Further allowed top coats:</p> <ul style="list-style-type: none"> <li>• Lacryl PU – Brillux</li> <li>• Fontecryl 10 – TIKKURILA</li> <li>• Dekontlack L – svt</li> </ul>
--	--

	<p><b>Recommended equipment:</b></p> <ul style="list-style-type: none"> <li>• Adhesive tape/masking film</li> <li>• Airless spray gun, brush and/or roller</li> <li>• Possibly mirror to check the coating</li> <li>• Wet film gauge or equal</li> <li>• Metal strip, plate or equal to measure the dry layer thickness</li> <li>• Electronic dry film thickness gauge</li> </ul>
--	---

	<p><b>Label</b></p> <p><b>Product No. 01229000</b></p>
--	--

## Fire protection for structural steel

with PYRO-SAFE FLAMMOPLAST SP-A2 and PYRO-SAFE Dekorlack SP 2 top coat

### 4. Application

- The surface (steel with preparation standard Sa 2 ½ in accordance with DIN EN ISO 12944-4) must be free of dust, grease and loose pre-coatings.
- Steel surfaces shall be protected from corrosion, the type depends on the environmental conditions.
- To guarantee a long-term adhesion of PYRO-SAFE FLAMMOPLAST SP-A2 a suitable pre-coating is necessary.
- In the case of existing adherent paints and primers, a suitability test must be carried out in accordance with the svt-test procedure (see on p.12). If required, a reference list of tested primers can be requested.
- If necessary, floors, walls, neighbouring components and labels shall be covered or masked with tape to protect them of the spray mist.
- For several work steps, appropriate drying times must be observed. The drying time between the work steps is at least 8 hours.
- PYRO-SAFE FLAMMOPLAST SP-A2 and PYRO-SAFE Dekorlack SP 2 top coat have to be processed at temperatures more than +5 °C and less than 85 % relative air humidity.
- When processing PYRO-SAFE FLAMMOPLAST SP-A2 pay attention to the dew point table (p.11).  
The surface temperature of the component to be coated shall be at least 3 °C above the corresponding dew point temperature.
- Material losses must be taken into account during application.
- PYRO-SAFE Dekorlack SP 2 top coat (or alternative top coat) shall be applied to PYRO-SAFE FLAMMOPLAST SP A2 at the earliest five days after the last spray application of PYRO-SAFE FLAMMOPLAST SP-A2.  
(Air temperature +23 °C / relative air humidity 65 ± 3%), lower temperatures / higher humidity may occur to extend the drying time.
- In case of a partial damage to the coating, either the entire coating or a part have to be done again.  
IMPORTANT: The project-related dry film thickness must be rebuilt.
- The dry film thicknesses of all coatings have to be measured  
(Primer, PYRO-SAFE FLAMMOPLAST SP-A2 main coating and PYRO-SAFE Dekorlack SP 2 top coat (or alternative top coats)).
- The results of the film thickness measurements shall be recorded in a protocol.

## Fire protection for structural steel

with PYRO-SAFE FLAMMOPLAST SP-A2 and PYRO-SAFE Dekorlack SP 2 top coat

### 4.1 Dew point table

This table shows at which surface temperatures (depending on air temperature and air humidity) condensate will be at the steel part.

Air temp. [°C]	Dew point temperatures in °C with a relative air humidity (rounded values) of:																
	20%	25%	30%	35%	40%	45%	50%	55%	60%	65%	70%	75%	80%	85%			
6	-					-4.5	-3.1	-2.1	-1.1	-0.1	0.9	1.9	2.7	3.6			
8	-					-2.7	-1.6	-0.4	0.7	1.8	2.8	3.8	4.8	5.7			
10	-					-6.0	-4.2	-2.6	-1.3	0.0	1.3	2.5	3.7	4.8	5.8	6.8	7.7
12	-					-4.5	-2.6	-1.0	0.4	1.8	3.2	4.5	5.6	6.7	7.8	8.7	9.6
14	-					-2.9	-1.0	0.6	2.2	3.7	5.1	6.4	7.6	8.7	9.7	10.7	11.6
15	-					-2.2	-0.3	1.5	3.1	4.7	6.1	7.4	8.5	9.6	10.7	11.7	12.6
16	-					-1.4	0.5	2.4	4.1	5.6	7.0	8.3	9.5	10.6	11.7	12.7	13.6
17	-					-0.6	1.4	3.3	5.0	6.5	7.9	9.2	10.4	11.5	12.5	13.6	14.5
18	-					0.2	2.3	4.2	5.9	7.4	8.8	10.1	11.3	12.4	13.5	14.6	15.4
19	-					1.1	3.2	5.1	6.8	8.3	9.8	11.1	12.3	13.4	14.5	15.5	16.4
20	-					1.9	4.1	6.0	7.7	9.3	10.7	12.0	13.2	14.4	15.5	16.5	17.4
21	-					2.8	5.0	6.9	8.6	10.2	11.6	12.9	14.2	15.4	16.4	17.4	18.4
22	-					3.7	5.9	7.8	9.5	11.2	12.5	13.9	15.2	16.3	17.4	18.4	19.4
23	-					4.5	6.7	8.7	10.4	12.0	13.5	14.8	16.0	17.3	18.4	19.4	20.4
24	-					5.4	7.6	9.6	11.3	12.9	14.4	15.7	17.0	18.2	19.2	20.3	21.4
25	0.5	3.6	6.2	8.5	10.5	12.2	13.8	15.4	16.7	18.0	19.1	20.2	21.4	22.3			
26	1.3	4.5	7.1	9.4	11.4	13.2	14.8	16.3	17.7	18.9	20.1	21.3	22.3	23.3			
28	3.0	6.1	8.8	11.1	13.1	15.0	16.6	18.1	19.4	20.9	22.0	23.2	24.2	25.3			
30	4.6	7.8	10.5	12.9	14.9	16.8	18.4	20.0	21.4	23.7	23.9	25.1	26.1	27.2			
32	6.2	9.5	12.2	14.6	16.7	18.6	20.3	21.9	23.3	24.7	25.8	27.0	28.2	29.2			
34	8.7	12.0	14.8	17.2	19.4	20.4	22.2	23.7	25.2	26.5	27.8	28.9	30.1	31.2			
36	12.8	16.2	19.1	21.6	23.8	22.2	24.1	25.5	27.0	28.4	29.7	30.9	32.0	33.1			

A safety factor of 3 °C shall be added to the respective value.

If the structural element has a temperature lower than the respective value (+ 3 °C), coating works should not be done.

# Fire protection for structural steel

with PYRO-SAFE FLAMMOPLAST SP-A2 and PYRO-SAFE Dekorlack SP 2 top coat

## 5. Suitability test of pre-coated steel surfaces

In practice, pre-coated steel profiles or old coatings which cannot be assigned unequivocally are frequently found.

### 1. Evaluation of the old coatings condition\*:

- Visual evaluation for tears, bubbles, wrinkles, flaking, or rust
- Testing of the mechanical adhesion by means of cross-cut test (ISO 2409)
- If necessary, removal of the coating in order to show rust underneath



### 2. Performance of the coating system under heat influence:

- The coating may not run, melt, peel off or bubble up during a five-minute fire test with a gas burner.

### 3. Adhesion of the intumescent coating on the surface:

- On the steel profile, a DIN A3-sized sample surface is coated with PYRO-SAFE FLAMMOPLAST SP-A2 (wet film thickness 500 µm). There may be no negative effects on the surface after 5 hours.
- After the complete drying of the fire protection coating, the adhesion to the surface must be tested and evaluated by means of a cross-cut test.

### 4. Test of the dried system for functional performance. The fire protection coating is flamed with a gas burner, the following criteria must be observed\*:

- Immaculate foaming
- No running or peeling off of the foam
- After the fire test, the foam adheres tightly to the surface



The suitability of the coating material can only be evaluated based on unambiguous test results. Should the results not be within the scope of the aforementioned criteria, the pre-applied coating must be removed.

Please contact the Central Technology Dept. of the svt Group of Companies for any further questions. Phone: +49 (0) 41 05 – 40 90 – 0.

\* The pictorial representations are examples. Results may differ visually.

# Fire protection for structural steel

with PYRO-SAFE FLAMMOPLAST SP-A2 and PYRO-SAFE Dekorlack SP 2 top coat

## 6. Application steps

### 6.1 Processing information

1. The coating can be done using airless spray painting  
PYRO-SAFE FLAMMOPLAST SP-A2 (nozzle bore > 0.019 inch = 0.48 mm)  
PYRO-SAFE Dekorlack SP 2 top coat (nozzle bore: 0.013 - 0.17 inch = 0.33 - 0.43 mm)

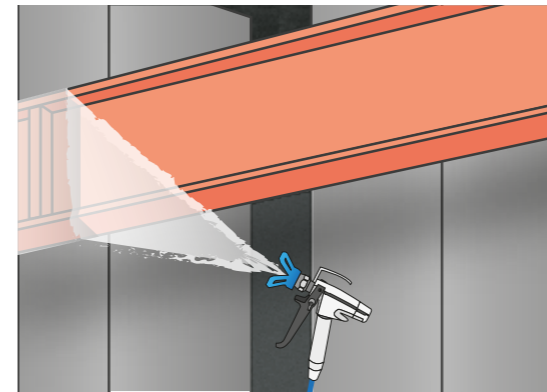

Alternatively, the steel can be coated by using a brush, roller or compressed air (PYRO-SAFE FLAMMOPLAST SP-A2 nozzle bore ≥ 3.5 mm, PYRO-SAFE Dekorlack SP 2 top coat nozzle bore 1.5 - 2.0 mm).

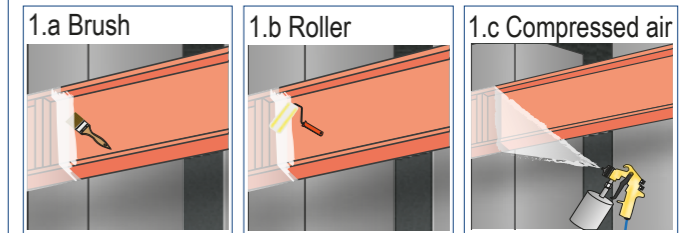

### 6.2 Preparation of the surfaces

If the component does not have a pre-coating so far, apply this according to the manufacturer's instructions and proceed with this instruction after the appropriate drying time.

If the steel part has an undefined pre-coating, the suitability has to be tested in accordance with p. 12.

1. Make sure the steel construction is free of any dust and dirt.

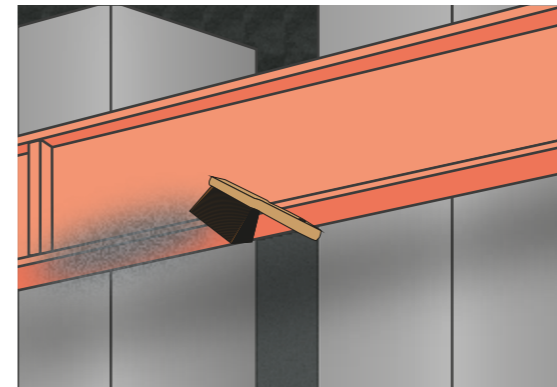

2. Stubborn dirt should be removed with water and neutral cleanser. Possible damages on the existing coating shall be repaired with a suitable corrosion protection coating.

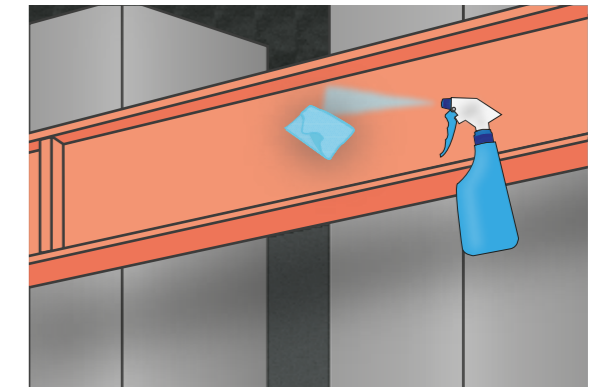

#### Note:

The cleaning and integrity of the pre-coating has a quality-determining influence!



## Fire protection for structural steel

with PYRO-SAFE FLAMMOPLAST SP-A2 and PYRO-SAFE Dekorlack SP 2 top coat

### 6.3 Film thickness measurement of the primer

The measurement of the dry film thickness preferably shall be done with an electronic dry film thickness gauge, after the cleaning and (possibly) repairing and before the coating procedure with PYRO-SAFE FLAMMOPLAST SP-A2.

1. Once the coating has completely dried out, use a dry film thickness measuring device to determine the thickness of the dry film.

Recommended: Use an electronic measuring device.

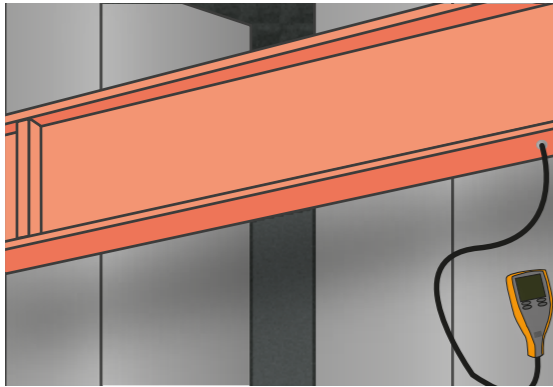

**Note:**  
Keep a record of the results calculated.

## Fire protection for structural steel

with PYRO-SAFE FLAMMOPLAST SP-A2 and PYRO-SAFE Dekorlack SP 2 top coat

### 6.4 Application steps PYRO-SAFE FLAMMOPLAST SP-A2

Any repair work on the existing coating must be at least 48 hours before the application can be started with PYRO-SAFE FLAMMOPLAST SP-A2.

1. Cover floors, walls, neighbouring components and labels with sheeting or mask them with tape to protect them from the spray mist.

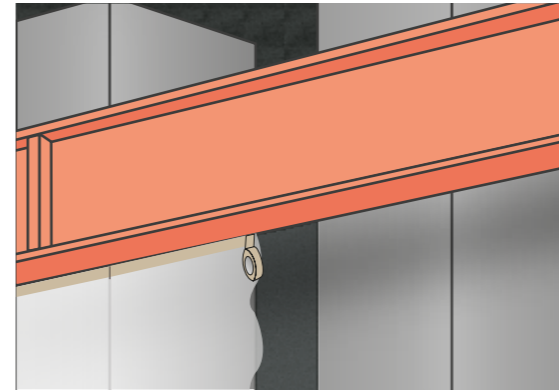

2. Using a stirrer attached to a drill machine. Stir the coating material thoroughly (minimum 5 min.) until it reaches the required handling consistency.



- 2.a After stirring, if the application consistency is still too thick, water can be added to thin it down slightly.



**Note:**  
The coating material needs to be stirred again every day.



## Fire protection for structural steel

with PYRO-SAFE FLAMMOPLAST SP-A2 and PYRO-SAFE Dekorlack SP 2 top coat

### 6.4 Application steps PYRO-SAFE FLAMMOPLAST SP-A2

3. Coat all exposed surfaces evenly with PYRO-SAFE Dekorlack SP-A2; either by painting with a brush or spraying, depending on the project specifications. Please follow the operating instructions for the airless spray gun!

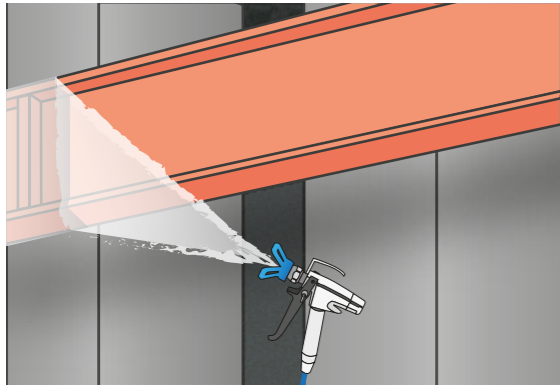

4. Hard to reach surfaces can be coated using the airless spray gun accessories, e.g. the extension tube and the linking nozzles.

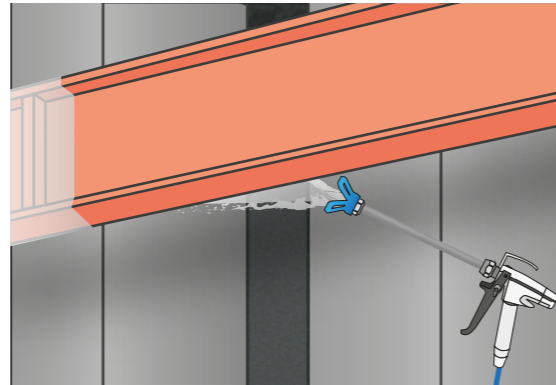

#### Note:

- Before coating it has to be checked if the steel is free of condensate, use the dew point table (p. 11).
- With a wet film gauge or equal, the coating thickness in wet condition can be measured to predict the thickness of the dry coating.
- While breaks, the tools like the airless spray gun, brush or roller should be stored in a bucket full of water to avoid surface drying of the coating material.

### 6.5 Film thickness measurement of the PYRO-SAFE FLAMMOPLAST SP-A2

1. Check that surfaces have been completely coated. Technical equipment can be used if necessary.

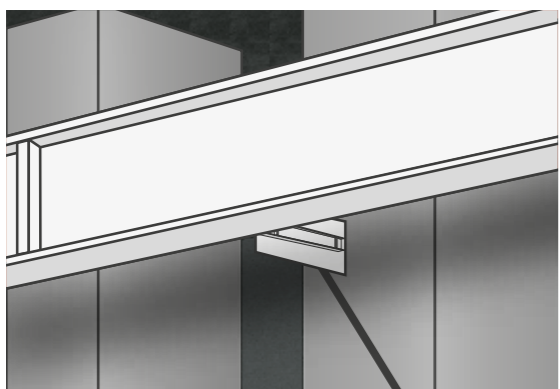

2. Once the coating has completely dried out, use a dry film thickness measuring device to determine the thickness of the dry film.

Recommended: Use an electronic measuring device.

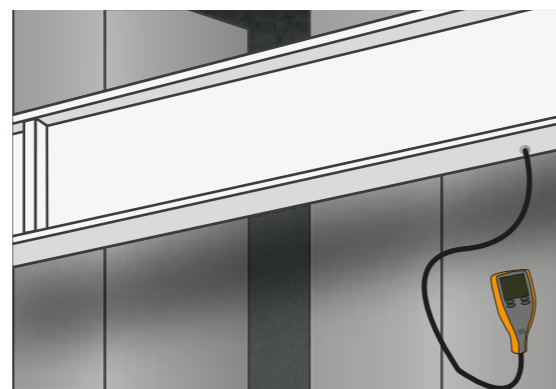

#### Note:

Hidden areas can be checked with a mirror.

#### Note:

Keep a record of the results calculated.

## Fire protection for structural steel

with PYRO-SAFE FLAMMOPLAST SP-A2 and PYRO-SAFE Dekorlack SP 2 top coat

### 6.6 Application steps PYRO-SAFE Dekorlack SP 2 top coat

If the prescribed dry film thickness is reached, PYRO-SAFE Dekorlack SP 2 top coat can be applied after a drying time of minimum 5 days after the last spray application.

The steel construction has to be free of any dust and dirt. Possibly, further cleaning of the parts in accordance with p. 13 is necessary before PYRO-SAFE Dekorlack SP 2 topcoat can be used for coating.

1. Using a stirrer attached to a drill machine. Stir the coating material thoroughly (minimum 5 min.) until it reaches the required handling consistency.



1.a After stirring, if the application consistency is still too thick, water can be added to thin it down slightly.



#### Note:

The coating material needs to be stirred again every day.

## Fire protection for structural steel

with PYRO-SAFE FLAMMOPLAST SP-A2 and PYRO-SAFE Dekorlack SP 2 top coat

### 6.6 Application steps PYRO-SAFE Dekorlack SP 2 top coat

2. Coat all exposed surfaces evenly with PYRO-SAFE Dekorlack SP 2 top coat; either by painting with a brush or spraying, depending on the project specifications. Please follow the operating instructions for the airless spray gun!

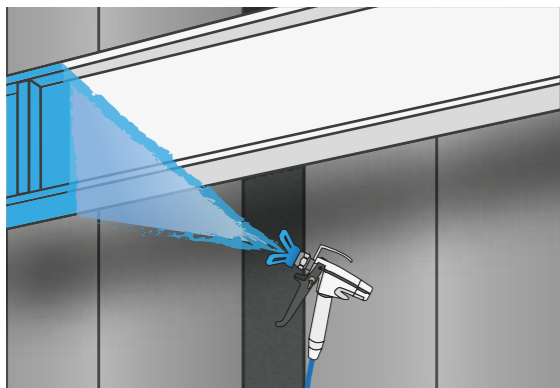

3. Hard to reach surfaces can be coated using the airless spray gun accessories, e.g. the extension tube and the linking nozzles.

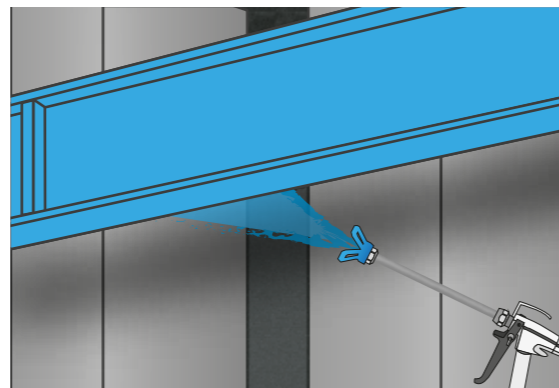

#### Note:

- PYRO-SAFE Dekorlack SP 2 top coat must be handled at over +5 °C and less than 85 % relative air humidity.
- The PYRO-SAFE Dekorlack SP 2 top coat is applied with a wet film thickness of app. 0.12 mm, which corresponds to a consumption of approx. 150 g/m<sup>2</sup> (material losses not contained). The wet film thickness can be determined with a measuring comb, after drying the dry film thickness is approx. 0.06 mm.

## Fire protection for structural steel

with PYRO-SAFE FLAMMOPLAST SP-A2 and PYRO-SAFE Dekorlack SP 2 top coat

### 6.7 Film thickness measurement of the PYRO-SAFE Dekorlack SP 2 top coat

1. Check that surfaces have been completely coated. Technical equipment can be used if necessary.

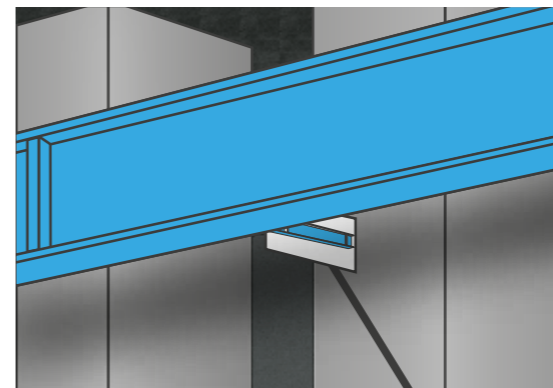

#### Note:

Hidden areas can be checked with a mirror.

2. Once the coating has completely dried out, use a dry film thickness measuring device to determine the thickness of the dry film.

Recommended: Use an electronic measuring device.

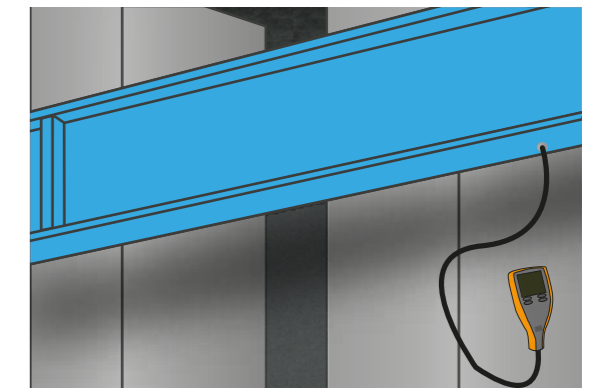

#### Note:

Keep a record of the results calculated.

3. Once the coating has completely dried out and the thickness of the dry film has been established, remove any tape and/or masking.

